

**2017 NDIA GROUND VEHICLE SYSTEMS ENGINEERING AND TECHNOLOGY
SYMPOSIUM
SYSTEMS ENGINEERING (SE) TECHNICAL SESSION
AUGUST 8-10, 2017 – Novi, MICHIGAN**

**SYSTEM INTEGRATION OF ADAPTIVE RESILIENCE IN REACTIVE ARMOR
SYSTEMS**

Joseph Cannon, Ph.D

US Army RDECOM

Tank Automotive Research, Development, Engineering Center (TARDEC)
Warren, MI

ABSTRACT

This study applies an augmentation to systems engineering methodology based on the integration of adaptive capacity, which produces enhanced resilience in technological systems that operate in complex operating environments. The implementation of this methodology enhances system resistance to top-level function failure or accelerates the system's functional recovery in the event of a top-level function failure due to functional requirement shift, evolutions, or perturbations. Specifically, this study employs a methodology to integrate adaptive resilience and demonstrates key aspects of its implementation in a relevant explosive reactive armor (ERA) system case study. The research and resulting methodology supplements and enhances traditional systems engineering processes by offering systems designers a method to integrate adaptive capacity into systems, enhancing their resilient resistance, or recovery to top-level function failure in complex operating environments. This research expands traditional and contemporary systems engineering, design, and integration methodologies, by explicitly addressing system adaptation and resilience. The utility of this research and methodology is demonstrated through integration of adaptive capacity in ERA, demonstrating how a single adaptive resilient design can have broader solution sets and enhanced performance against the myriad of threats this technology defeats.

INTRODUCTION

Systems engineers design, develop, and field traditional systems to address a set problem or fixed set of requirements that the system's functionality solves or fulfills. These traditional systems tend to operate at one optimized design point for a given set of external operational conditions to achieve a given top-level function or task. This approach, while acceptable for most systems, presents a significant functional limitation for systems that must operate or function in complex environments. Complex environments can be defined as environments in which operational conditions are unpredictable, experience disruptive perturbation, and rapidly shift.

This research builds on a recently introduced system attribute called adaptive resilience, which enables a system to adapt its functional traits, structure, process, and/or identity in order to maintain or regain functional effectiveness in satisfying its top-level functional requirements. This attribute is particularly beneficial in complex operating environments. In order to achieve an adaptive resilient system, system designers and engineers must identify, account for, and incorporate the necessary range or capacity for adaptation early in the design and development process.

FAULTS WITH TRADITIONAL AND CONTEMPORARY SYSTEM DESIGN

All technological systems operating in complex environments are disadvantaged when they encounter operational circumstances that may cause them to fail to achieve and maintain their top-level function. Traditional static system designs often fail in complex operating environments due to their inability to readily adapt to changing functional requirements. This is shown in Figure 1.

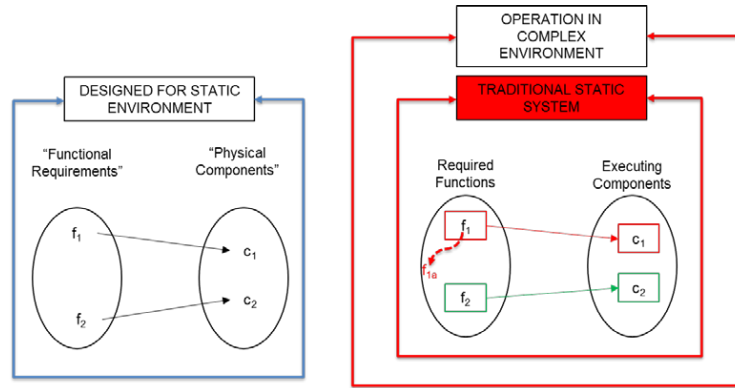

Figure 1. Traditional/Static System Design in Complex Operating Environments.

This figure depicts how a statically-designed system, when placed into a complex operating environment will likely fail from rapid functional requirement evolution. System components are typically mapped to system functions. Fixed, optimally-designed components cannot accommodate functional requirement shifts (depicted with red dashed path) causing them lose their ability to fulfill the system’s designed functionality. Adapted from [1]

Contemporary fixed system designs (design for robustness) are better suited for operation in uncertain environments. However, they likely possess parasitic capacity created by their robust nature and are ultimately susceptible to failure in complex environments because they also employ fixed functional states. Parasitic capacity is underutilized functional capability that detracts from adjacent functional capabilities within a system. This is shown in Figure 2.

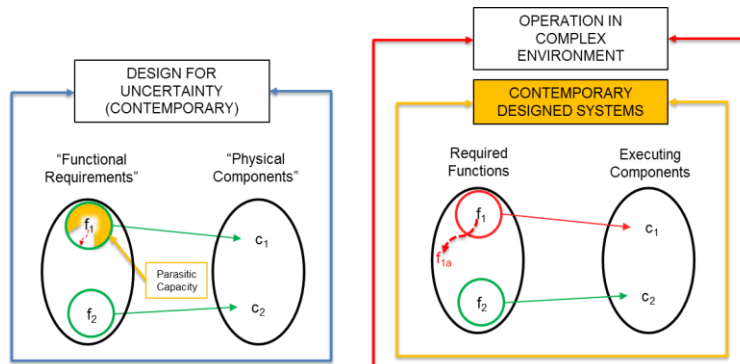

Figure 2. Contemporary System Design in Complex Operating Environments.

This figure depicts how contemporary designs have enhanced robustness (broad circular line around requirement) to the uncertainty of complex environments. However, in achieving this robustness the system traded away optimal performance in certain functions to achieve a level of performance for a broader set of functions. This situation often creates parasitic capacity (depicted in yellow) where the broader system capacity that is created or enabled by trades, seldom gets employed. This makes the functions that are employed more often perform in a less than optimal state. Ultimately, robust system designs are still likely to employ static components and will encounter circumstances where their functional requirements will shift, rendering the components incapable of functional accomplishment. Adapted from [1]

Adaptive resilient system designs possess adaptive physical components that enable the system to resist or recover from functional failure in complex operating environments in an agile fashion, while simultaneously mitigating the effects of parasitic capacity. This is shown in Figure 3.

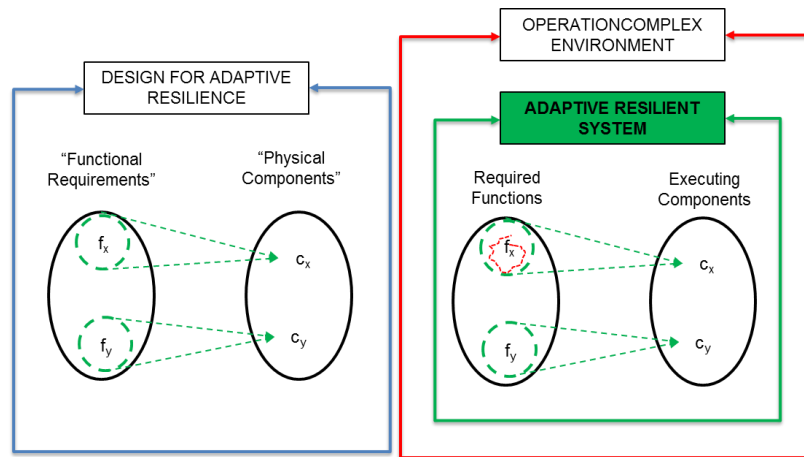

Figure 3. Adaptive Resilient Design in Complex Operating Environments.

This figure depicts how an adaptive resilient system overcomes the challenges associated with operation in complex operating environments by creating a range of suitable functional performance (f_x) enabled by adaptive physical components (c_x vice c_1). The range of functional performance (dashed ring) provide functionality in an extensible fashion beyond the functional requirement, or just enough to satisfy the requirement while still allowing maximum efficiency within the design. Furthermore the system adapts to the design point that is most optimal for the functional need at hand. In doing this the effects of parasitic capacity are mitigated. Adapted from [1]

ADAPTIVE RESILIENCE

Within a system, adaptability is the key element that produces resilience. A system can only adapt to a purpose or a situation if it has the capacity to adapt or if some means of intelligence externally influences the system to adapt its use to new ends. Adaptive capacity is the critical system attribute that produces system resilience [2]. Adaptive capacity can be defined as the extent to which a system can adapt or absorb a functional disturbance without completely losing operational performance of a top-level function [2]. Adaptive capacity can be further decomposed into modes of adaptability. Modes of adaptability are the ways and means to restructure or reconfigure a system's functional traits, structure, process, and/or identity. Two modes of adaptability—Adaptive Mode 1: Internal Reconfiguration and Adaptive Mode 2: External Reconfiguration—serve to achieve the desired adaptation. Adaptations that occur through internal reconfiguration utilize means such as processes, mechanisms, and artifacts within the system to achieve desired functionality. External reconfiguration involves the use of external means to achieve desired system functionality. Adaptive Mode 1 includes adaptive means present within the system at the time of the functional disturbance or incident. Adaptive Mode 2 involves the use of external means (e.g., mechanisms, processes, and artifacts) not present in the system when its functionality was lost, but when applied after the fact, allows the system to regain its functionality.

In a systems engineering context, resilience is a system attribute that describes the system's ability to withstand or recover from perturbations and disruptions that exceed its functional tolerance. Resilience is a system state of being, without which a system would fail under the slightest external influence. Resilient ends are brought about by adaptive ways and means that exist in a system.

Adaptive resilience is the combined result of resilience achieved from system adaptation. It is the system attribute that enables a system to adapt its functional traits, structure, process, and/or identity in order to maintain or regain functional effectiveness in satisfying its top-level functional requirements. The conceptual need for adaptive resilience stems from the growing complexity present in modern system operating environments. As previously discussed, traditional and contemporary technological systems are developed and fielded with a set problem or static set of requirements that the system's functionality solves or fulfills. This approach, although acceptable for most systems, presents significant functional limitations for systems required to operate in complex environments where those external operational conditions are unpredictable, experience perturbation, or rapidly shift; like armor on vehicle platforms in combat.

INTEGRATING ADAPTIVE RESILIENCE

The methodology for the system integration of adaptive resilience (MSIAR) builds on prior design approaches and paradigms such as axiomatic, allocated design, set-based design, as well as aspects of Model-Based Systems Engineering (MBSE), and trade-space analysis to mitigate the consequences of uncertainty in the system's functional design. The MSIAR transcends these methods by placing emphasis on the adaptive resilient physical component design. By doing this the components are enabled to accommodate a broader range of functional requirements while simultaneously mitigating the effects of parasitic capacity. Figure 4 shows the integration methodology that is the focus for this research. The methodology utilizes seven high-level steps that can be decomposed to any requisite level of fidelity for the integration effort of interest. The seven steps are as follows:

1. Define adaptive design considerations
2. Identify controllable/adaptive performance factors
3. Characterize adaptive performance factor configurations
4. Verify and validate adaptive performance factor configurations
5. Map validated configurations to adaptive system components/modules
6. Integrate adaptive components and configurations into system
7. Verify and validate integrated component configurations and performance

In this study, only three steps of the seven-step methodology were applied to the design of a novel reactive armor system. Only steps one, two, three, and five were applied since they are most salient to the adaptive system design, engineering and integration. Furthermore, steps four

and seven would require the use of threats and threat performance data against an actual armor design, requiring a higher security classification and thus limiting the public distribution of this study.

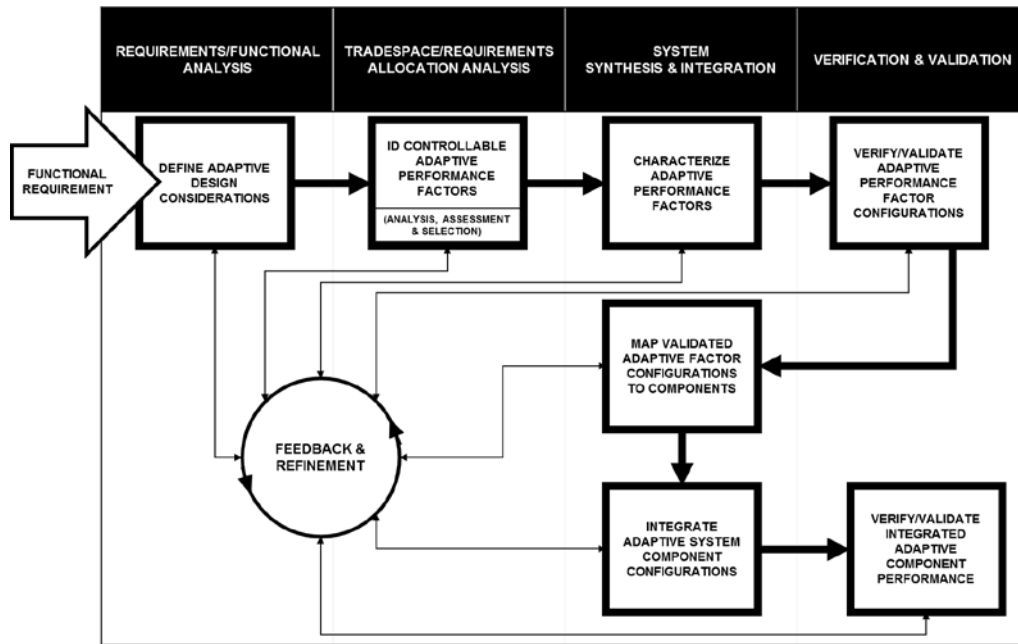

Figure 4. The Methodology for the System Integration of Adaptive Resilience.

This methodology supplements the steps of the existing systems engineering process approaches to incorporate the adaptive capacity necessary for a system to attain functional resilience. Only Steps 1, 2, 3, and 5 will be discussed in this study. Reused from [1]

ADAPTIVE RESILIENT REACTIVE ARMOR

For this application of the MSIAR, some background technical information must be laid out to maximize comprehension of the system engineering concepts. A basic description of the threats and functionality of Explosive Reactive Armor (ERA) is provided to give context to the discussion of adaptive performance factors.

Threat Background:

Shaped charge jets (SCJ) and explosively formed penetrators (EFP) are commonly used munitions for penetrating armor. The deepest penetrating shaped charges, employ a hollow cavity which is lined with a thin contiguous layer of dense metal or some other solid. During the detonation of the explosive, this liner collapses in a symmetrical fashion towards a concentration zone. Here the material simultaneously slams into the opposite side of the collapsing cone and is ejected in a ray along and out of the center axis of the conical or cylindrical cavity. This ejected material, often referred to as a jet, is moving at speeds ranging anywhere from 3280 to 32808 feet per second (based on their cone angle, explosives, and mass of the liner) [3]. At these speeds and forces, the stress and strain rate inside of the liner material causes the solid material to behave like a fluid [3]. Furthermore, a velocity gradient in the ejected liner causes the flowing liner to compress and elongate, which can result in higher penetration potential. Under optimal

conditions, this elongated liner can create very deep penetrations into armor materials. As seen in Figure 5, the cone angle has significant effect on how the shaped charge projectile penetrates. Shallow cone angles, 180 to 120 degrees, tend to create slug like projectiles. These projectiles do not continuously elongate to the extremes seen in the deeper cone angles, but rather break up into multiple axially aligned particles of varying mass. While these projectiles do not penetrate as deep as SCJ, they are relatively stable in flight and are able to transmit a large amount of kinetic energy into their targets. The shaped charges with deeper cone angles, 120 to 80 degree, show extreme elongation in their projectiles. This elongation gives the deeper cone projectile far greater penetration capability. This penetration depth often exceeds multiple cone diameters into a target. A drawback to the deeper, narrower-angled shaped charges are their low aero-stability in flight, limiting their effective standoff compared to the obtuse cone angles.

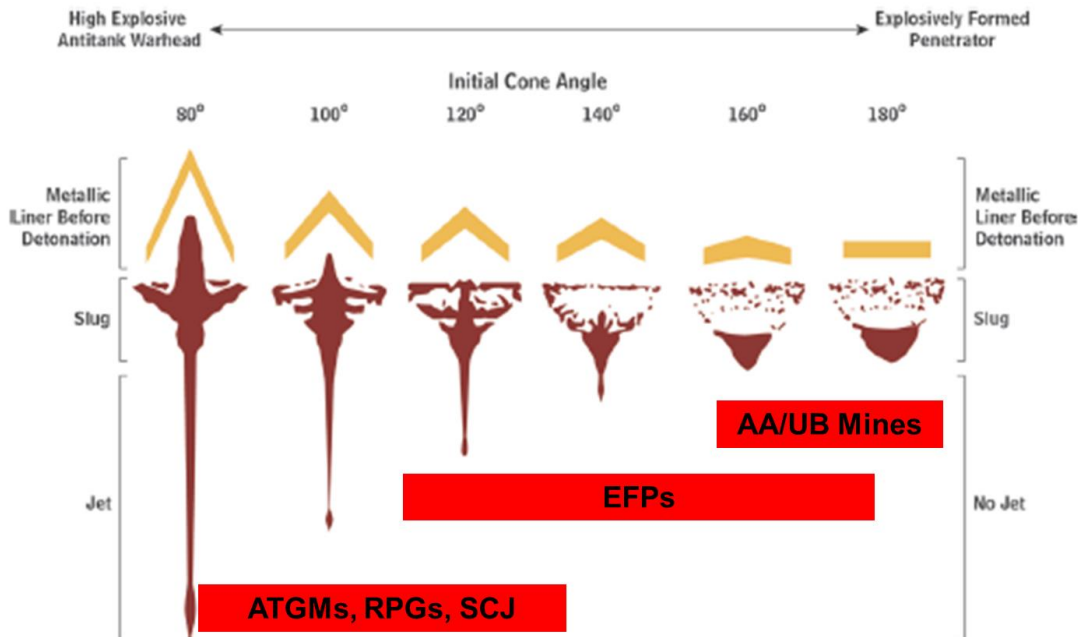

Figure 5. Shaped Charge Cone Angle Slug and Jet Formations.

This figure depicts the various jet and slug formations associated with different shaped charge copper liner cone angles. Sharp cone angles result in narrow, contiguous, but very high speed jet/slug combinations. Flat cone angles tend to create slug like projectiles with a longer stream of disparate particles moving at various decreasing speeds. The notional threats used for this study, EFP and SCJ, are completely made up but have characteristics consistent with the 140° and 90° angle range respectively. Adapted from [3]

For this study and classification reasons, two notional shaped charge (SC) -type threat projectiles will be employed to give context and mathematical rigor to the proposed integration of adaptive resilience in reactive armor. These notional threats were randomly formulated with metrics that are representative to real threats but with no traceability to a real threat. The two threats are shown in Figure 6. The notional SCJ threat consists of 500 mm or 1.64 feet copper rod with a .25 inches diameter. This rod will notionally travel at a speed of 5 km/s or 16404.2 ft/s. The notional EFP threat consists of three copper cylinders with lengths of 6 inches, 3 inches, and 1 inch, diameters of 2 inches, 1 inch, and .5 inches respectively. The cylinders are axially aligned and spaced at 6

inches and 12 inches respectively. The combination of cylinders is travelling at 8202 ft/s. For simplicity sake, no velocity gradient is present within either threat train (EFP, SCJ) of particles.

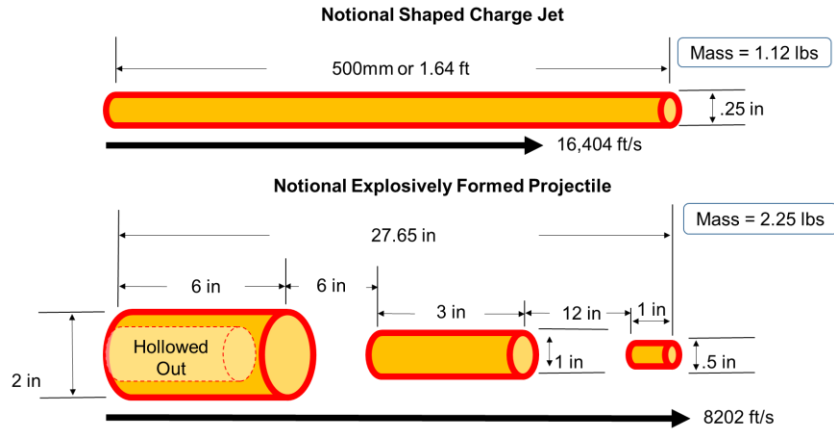

Figure 6. Notional SCJ-Type and EFP-Type Threats.

This figure depicts the notional SCJ-type (top) and EFP-type (bottom) threats that were made up for the adaptive factor characterization portion of this study. Notional threats were used to avoid classification constraints that would have limited the distribution of this study.

Explosive Reactive Armor Background:

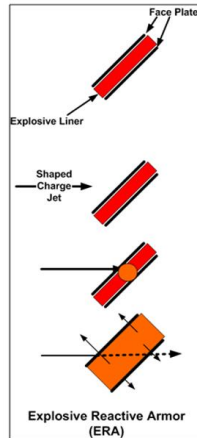

Figure 7. Explosive Reactive Armor.

This figure conceptually depicts the functional operation of Explosive Reactive Armor. ERA employs solid material plates driven apart by sheet explosives. The solid material plates disrupt the threat particles that trigger the armor dynamic motion. Source [4]

Explosive reactive armor (ERA) is a widely proliferated and mass efficient approach toward disrupting and reducing the heavy penetration of SCJs and EFPs. There are numerous types of ERA, but most employ the same fundamental mechanism for threat defeat. This mechanism is a simple assembly of two sheets or plates of solid material laminated together by a thin sheet of explosive. As seen in Figure 7, the jet or slug of the shaped charge detonates the sheet of explosive when it strikes the ERA Cassette. The explosive detonation drives the two plates of solid material apart at a very high velocity. This opposing motion of the two sheets impinge the

length of the jet or slug(s) with unaffected armor material [5]. This plate driving action can be kinetically characterized by the Gurney Model [6]. The Gurney Model can be applied to numerous explosive-plate geometries. Contemporary ERA designs are best supported by symmetrical sandwich configuration and the asymmetrical sandwich configuration Gurney models shown in Equation (1) and (2) [6].

$$(1) \text{ Symmetrical Model: } V = \sqrt{2E} \left(2 \frac{M}{C} + \frac{1}{3} \right)^{-\frac{1}{2}}$$

where :

$M = \text{Plate Mass}$

$C = \text{Explosive Mass}$

$E = \text{Explosive Detonation Velocity}$

$$(2) \text{ Asymmetrical Model: } V = \sqrt{2E} \left(\frac{1+A^3}{3(1+A)} + \frac{N}{C} A^2 + \frac{M}{C} \right)^{-\frac{1}{2}}$$

where :

$$A = \frac{1 + 2 \left(\frac{M}{C} \right)}{1 + 2 \left(\frac{N}{C} \right)}$$

$M = \text{Front Plate Mass}$

$N = \text{Tamping Plate Mass}$

$C = \text{Explosive Mass}$

$E = \text{Explosive Detonation Velocity}$

Contemporary ERA employ fixed performance factors and therefore fixed components. These contemporary systems are designed in a very robust way which allows for maximum applicability across the SC spectrum (cone angles and diameters). This approach comes at the expense of parasitic capacity in the form of excess mass, volume, and capability. This parasitic mass and volume degrades the host platform's tactical and strategic mobility. Despite this robust design, a single ERA design can protect against a fraction of the SC spectrum. The fixed contemporary ERA designs are limited in their ability to adapt to emerging SC threats in operationally relevant time scales. This means that a simple change in the copper liner diameter, mass and cone angle of a shaped charge threat could render an ERA unable to mitigate its lethal penetration. Other shortcomings that must be considered include the parasitic protective capacity often provided to the host platforms and the explosive charge collateral effects. ERA is typically used for the most penetrating threats and not all operational scenarios require this level of protection. The explosive means of protection associate with ERA creates risk for collateral effects on the platform and surrounding areas. Additionally, once integrated it seldom is removed due the shear amount of effort installing it. In order to mitigate these

shortcomings associated with ERA, novel reactive armor designs are proposed which have broader threat applicability, limited parasitic capacity, minimal collateral effects and minimal impacts to host platform mobility. This is where adaptive resilience can enhance this mature technology and provide greater capability while mitigating the known drawbacks.

MSIAR Step 1: Define Adaptive Reactive Armor Design Considerations

As previously discussed, ERA has select shortcomings that provide opportunity for adaptive resilient enhancement. Vehicle armor protection requirements are generally classified, therefore a notional need statement to start the MSIAR process is provided below:

“A novel reactive armor is needed which has broader threat applicability, limited parasitic capacity, and minimizes impacts to host platform mobility.”

This statement can be further decomposed into the following notional specifications

- 1. ERA system must be capable of adapting its explosive tri-plate obliquity, in real-time from 30° to 75° angles which provide enhanced threat disruption over broader portion of the SC cone angle spectrum.**
- 2. ERA system must minimize volume and mass added to the host platform it protects, or have a means to mitigate impacts to tactical and strategic mobility in operationally relevant timescales.**
- 3. ERA must possess the means to rapidly down-scale or up-scale protection to mitigate parasitic capacity or rapidly respond to threat overmatch respectively.**

An ERA system with these considerations accounted for in its design would provide significant functional resilience in the face of threat or operating condition changes. Contemporary ERA designs are very limited in their ability to address the needs statement or the capability enhanced specifications listed above. With the adaptive design considerations identified, the ERA system designer can now transition to MSIAR step 2: Identify Controllable Adaptive Reactive Performance factors.

MSIAR Step 2: Identify Controllable Adaptive Reactive Armor Performance Factors

With the adaptive design considerations defined, the controllable or adaptive performance factors must now be identified to determine suitable armor system parameters to be manipulated to achieve the adaptive design considerations. Functional parameters or factors are independent attributes of a function that dictate the performance or output of that function. In other words, this step of the methodology identifies the controllable independent performance variable(s) on which the adaptive function depends. Controllability is critical, because if the factor or parameter cannot be actively manipulated, then the user cannot adapt it for the desired performance.

When seeking controllable adaptive performance factors, a good starting point is the oppositional

performance factors within a system. Oppositional performance factors are diametrically opposed factors where growth in one typically results in loss in another and vice versa. These factors present prime opportunities for integration adaptive resilience. They constrain and provide definition to the functional trade space, and often that trade space can be physically exploited by adaptable components.

Armor systems derive their fundamental functionality from the transfer of momentum from threat to the armor system. The physics of armor and threat interaction are governed by the law of conservation of energy. The key factors driving threat and armor performance are the armor material properties, armor mass, armor dimensionality, and physics of the threat and armor interaction (kinetic energy and momentum). Thinking adaptively, threats employ a range of masses, accelerated to a range of velocities, to achieve a range of kinetic energies, to penetrate an assortment of armors. An armor designer who can effectively manipulate these same factors in a meaningful and timely fashion can create adaptive reactive armor technology to prevent a threat's penetration. Traditional armor designs use a material with a fixed material mass bolted onto a vehicle in some dimensional configuration that statically absorbs the kinetic energy or momentum (velocity, dimensionality, and mass) of the incoming threat upon its impact. So an adaptive resilient armor with the ability to manipulate its mass, dimensionality, and velocity over a range of values in operationally relevant timescales would be considered adaptively resilient. In an ERA, it is possible to rapidly adapt the armor systems dimensionality, mass, and velocity in a predictable fashion, therefore these adaptive performance factors are the suitable and controllable.

Characterize Adaptive Performance Factors.

Three adaptive performance factors were identified as ways to bring about adaptive resilience in an ERA system. It is generally understood that these factors have impacts on the ballistic performance of an ERA. To better align these ways to suitable means, quantitative understanding of their effect on performance must be achieved. For the purposes of this study, abbreviated characterization will be conducted at select factorial design points that capture the essence of how adaptive capacity realized from adaptive performance factors can enhance performance.

ERA plate mass and explosive mass play a critical role in the performance of an ERA system. ERA systems dynamically drive mass into an oncoming threat. The amount of mass in the plates and explosives determines the rate at which this armor mass is fed into an oncoming threat mass. For this case study we will analyze just two simple ERA triplate sandwich arrangements; one symmetrical and one asymmetrical. The symmetrical arrangement is composed of two 1-foot-square plates of RHA and one 1-foot-square sheet of Deta-Sheet explosive, all at .25 inches thick. This ERA arrangement generates dynamic plate response shown in Figure 8.

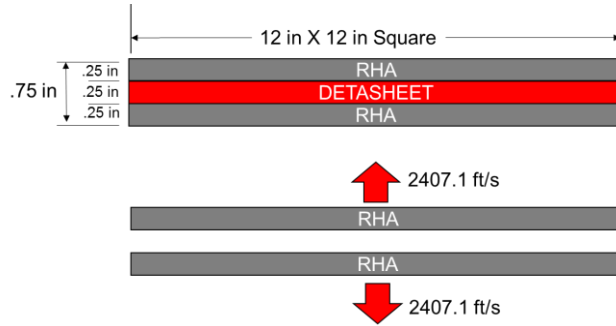

Figure 8. Explosive Reactive Armor Gurney Application: Symmetrical Triplate. This figure depicts the resultant Gurney Velocities calculated for a .25 in-symmetrical triplate (All sheets are .25 in). The resultant velocity is 2407.1 ft/s in opposing directions.

The asymmetrical sandwich with the same area and explosives dimensions but with one of the plates changed to .5 inches thick generates a dynamic plate response shown in Figure 9.

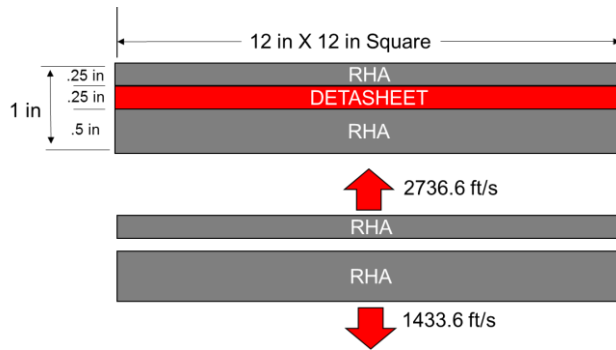

Figure 9. Explosive Reactive Armor Gurney Application: Asymmetrical Triplate. This figure depicts the resultant Gurney Velocities calculated for a .25-.25-.5 in asymmetrical triplate. The resultant velocity is 2736.6 ft/s for the front plate and 1433.6 ft/s for the tamp/rear plate in opposing directions.

Figure 10 depicts symmetrical and asymmetrical ERA triplate configurations and their associated Gurney velocities.

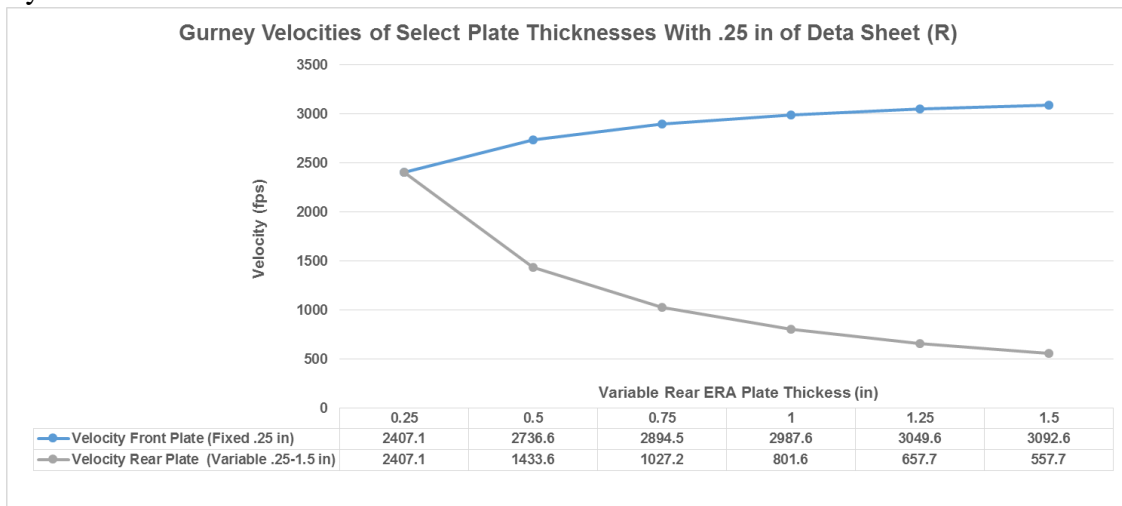

Figure 10. Gurney Velocities of Select Plate Thicknesses.

It is readily evident how changing the plate mass affects the dynamic response of the ERA system. In ERA, plate mass not only affects the speed of a plate but also the speed of the opposing plate. Changing the mass of the explosive or type of explosive also has dynamic effects on the kinetic response of the ERA. A symmetrical sandwich with the same area and plate dimensions but with explosive Deta-Sheet changed to .5 thick generates a dynamic state shown in Figure 11.

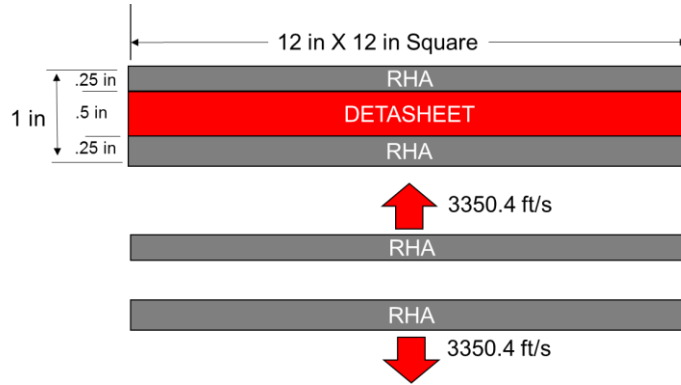

Figure 11. Explosive Reactive Armor Gurney Application: Semi-Symmetrical Triplate. This figure depicts the resultant Gurney Velocities calculated for a .25 in-symmetrical Steel triplate however the explosive Deta Sheet thickness was doubled to .5 in. The resultant velocity is 3350.4 ft/s in opposing directions.

Figure 12 depicts .25 in thick symmetrical ERA 12 inch by 12 inch triplate configuration and their associated Gurney velocities as the explosive charge mass is increased.

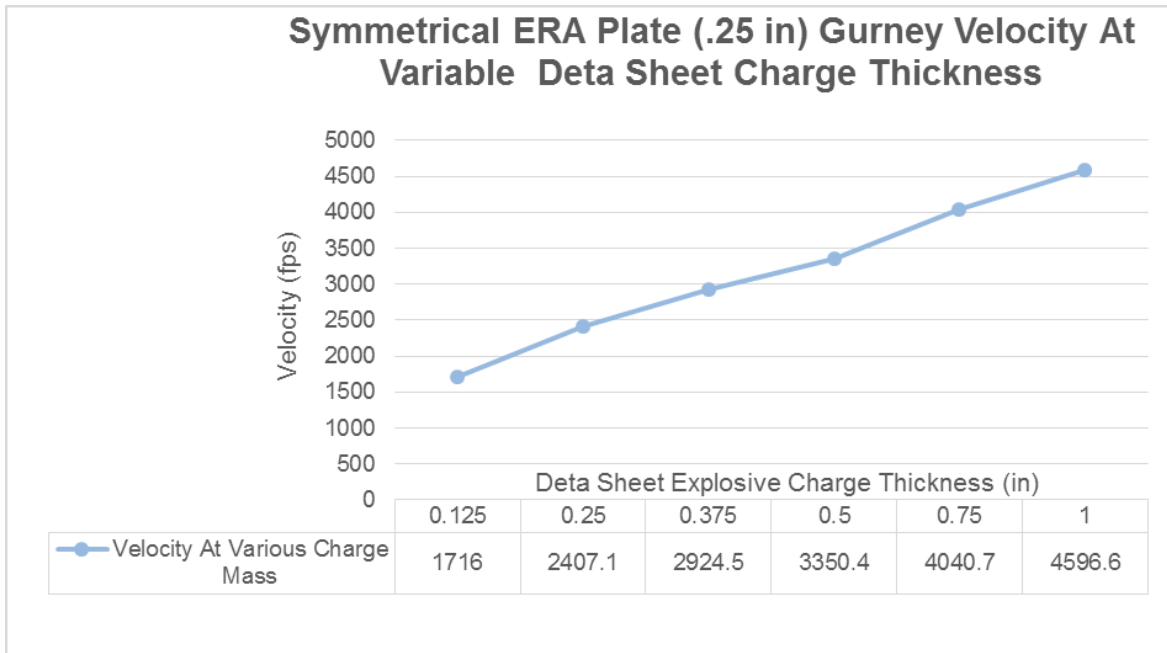

Figure 12. Symmetrical ERA Plate Gurney Velocity as variable Deta Sheet Charge Thicknesses.

In a non-dynamic sense, the plate mass also has an impact on the weight of the armor system. The heavier the armor system, the more effect it has on the tactical and strategic mobility of the host platform the armor is protecting. More armor mass generally means more protective capability, but less mobility. Less mass means more mobility but less protection. In a terminal ballistic context mass enhances system performance, in a vehicle mobility context mass inhibits system performance. Mass is a oppositional performance factor

Dimensionality of an ERA system is another factor that has an oppositional relationship that affects both vehicle ballistic protection and mobility. As previously stated, fixed ERA design consume large amounts of volume on a vehicle hull. This consumed volume often restricts a vehicle to select airframes for strategic mobility and restricts the width of mobility corridors the vehicle can traverse in its operating environment. That same volume provides the needed temporal and spatial needs for the ERA system to effectively disrupt incoming threats. This presents engineers and designers with a dichotomy, trade away protection for mobility or mobility for protection. Dimensionality in an ERA system is driven by the triplate obliquity. Steeper triplate obliquity provides suitable performance for slower and longer threats while minimizing dimensionality. Shallow obliquities are suitable for faster and shorter threats which usually require more dimensionality. Both types are often needed and both types have host platform impacts on mobility.

In an effort to discuss this matter without crossing classification thresholds, mathematical approximations will be conveyed which show the dichotomies of ERA obliquity with threats and mobility. The following figures and graphs utilize notional threat mass, temporal, and spatial attributes in comparison to ERA triplate dynamic mass, spatial, and temporal attributes at different obliquities. No mechanics of materials, failure mechanics, or other terminal ballistic evaluation approaches were employed to characterize these adaptive factors. The author recognizes these approaches but did not utilize them in order to prevent classification constraints which would have limited the distribution of this study.

A given threat travels on a trajectory and intersects an oblique ERA triplate. The threat-triplate impact initiates the reactive armor and a dynamic event occurs. During this event the threat particle mass continues to travel along its original trajectory colliding with the dynamic triplate action. Simultaneously the oblique ERA triplate separates and different portions of the diverging triplates interact with the different portions of the threat at different times.

Different triplate obliquities and mass arrangements have different interaction times and durations with the threat mass, trajectory, and velocity. Shallower obliquities have rapid interactions and durations with this trajectory. Steeper obliquities have prolonged interactions and durations with the threat trajectory. Hence, faster shorter threats are more suitable for shallow triplate obliquities, and slower or longer threats are more suitable for steeper triplate obliquities. See Figure 13 for a graphic depiction of this concept. A steep triplate obliquity would have minimal plate-mass interaction with a shorter faster threat. A shallow triplate obliquity would have significant plate interaction with the early particles of a slower elongated threat, but may miss the slower tail end particles.

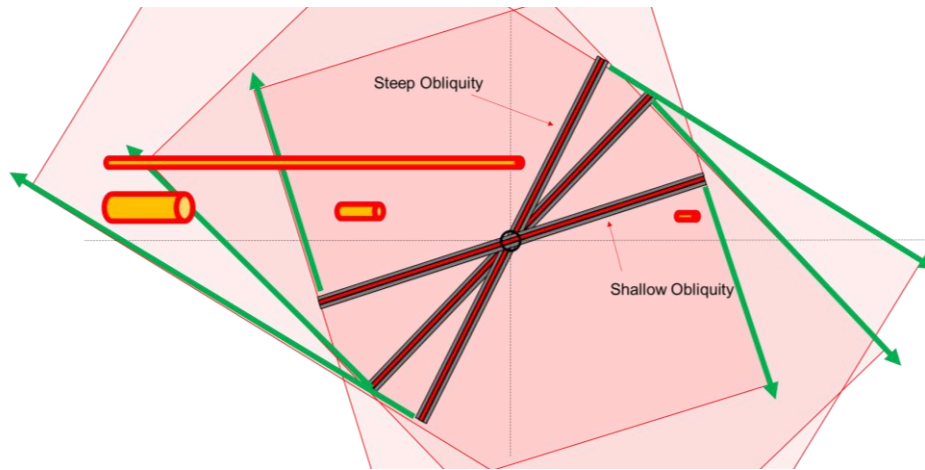

Figure 13. Conceptual Depiction of ERA and Threat Interaction.

This figure depicts how different ERA-threat-interaction obliquities result in different interactions with the threat. Shallow obliquities place a high armor mass in the trajectory for short period of time but could miss slower portions of the threat. Steeper obliquities place less armor mass in the threat trajectory but grow the duration of mass in the trajectory.

The following graphs numerically show this concept. Figure 14 shows two triplate cassette arrangements (see Figure 8 and 9) in dynamic events immediately following both the notional EFP and SJC threats impacting at a 90° horizontal to the ground and at 50% of the vertical height of the oblique triplate cassette. Any coincidental time percentage less than 100% indicates that dynamic triplates moved too fast for the given threat and portions of the threat were not necessarily affected by the ERA. Any value over 100% indicates that the dynamic triplates had equivalent or greater coincidence with the threat. 200% would indicate that triplates had twice as much needed coincidence time with the threat. Note the color-shaded areas on the graph. This indicates ideal zones of time coincidence; green being most ideal, yellow being satisfactory and red meaning not ideal. For time coincidence the plates should have at minimum equivalent (100%) play time with the threat, and at most four times the play time (400%). Any less time, and significant portions of the threat are not being interacted by the ERA. Any more time and minimal ERA mass is interacting the threat. From an obliquity perspective, 20°-60° are ideal obliquities for the shorter, faster SCJ-type threats from a “coincidence time” perspective. Whereas the 45°-75° is ideal for the slower, elongated EFP-type threat from a “coincidence time” perspective.

One aspect to note is the asymmetrical plate time coincidence. Asymmetrical triplates offer a means to create triplate dynamics that can be both fast and slow. The lighter plate, having a high velocity can be used to disrupt faster moving early particles of an SCJ threat. The heavier plate, with a slower velocity can be used to disrupt slow particles that lag behind the faster lead particles. Asymmetrical triplates provide a user a robust approach to dealing with variable particle speeds in a threat scenario.

Mass coincidence is the other factor that will be characterized for this step. Mass coincidence takes the triplate mass interacting with the total threat mass and gives a percentage based on the obliquity of interest.

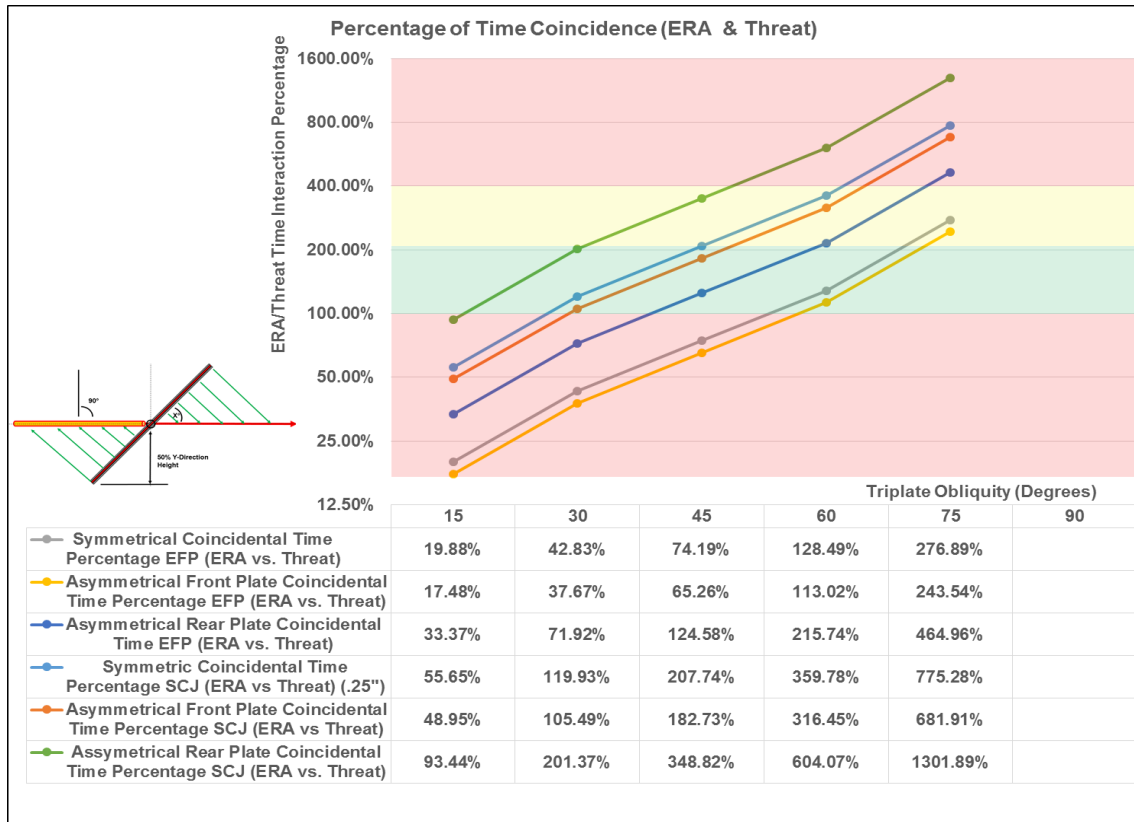

Figure 14. ERA-Threat Time Coincidence.

This graph depicts the percentage of time that ERA plates are interacting with the trajectory of the threat. Any coincidental time percentage less than 100% indicates that dynamic triplates moved too fast for the given threat and portions of the threat were not necessarily affected by the ERA. Any value over 100% indicates that the dynamic triplates had equivalent or greater coincidence with the threat. 200% would indicate that triplates had twice as much needed coincidence time with the threat. The optimal time coincidence range for ERA obliquities for SCJ and EFP-type threat spans from 20°-75°

The threat-armor-interaction scenario is the same as described in Figure 14. Mass coincidence is more difficult to analyze because the threats have different masses. For example, the two notional threats have significantly different masses; 2.25 lbs. vs. 1.12 lbs. Therefore the coincidental mass percentages will show disparity. For the SCJ-type threat, the ideal obliquity range for ERA was shown to be from 15°-45°. For the EFP-type threat, the larger mass percentage is shown in the 15° and 30° obliquity range. This is true that more of the ERA mass is in play, but recall the EFP threat is segmented. The 15°-30° range of obliquity shows a flat/level trend for the EFP-type threat because the dynamic triplates had placed their complete mass in the trajectory of the threat. Compare this with the time coincidence, it becomes evident that portions of the threat were completely missed by the dynamic triplates. In the 45°-60° obliquity range it is shown that the complete ERA mass was not placed into the trajectory meaning that the complete EFP-type threat had a dynamic triplate mass interacting with its

trajectory. This indicates that the ideal obliquity range for the notional EFP-type threat is 45°-60°.

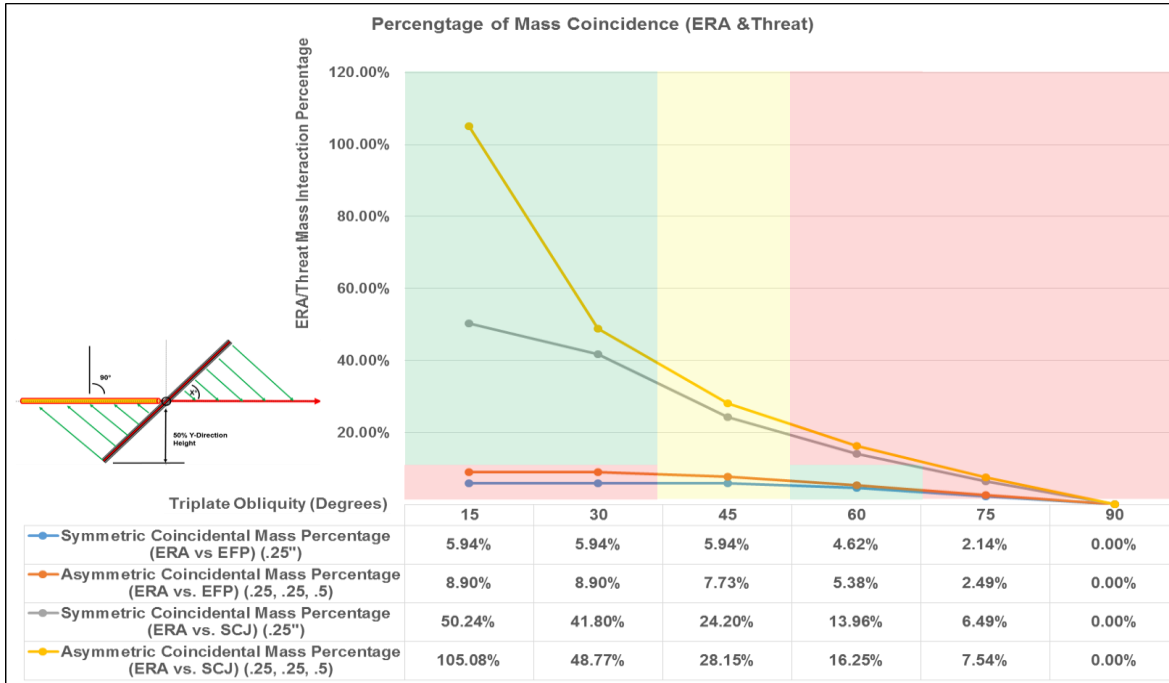

Figure 15. Explosive reactive Armor conceptualization. This graph depicts the percentage of mass the ERA plates interacting with the trajectory of the threat. The optimal mass coincidence range for ERA obliquities for SCJ and EFP-type threat spans from 15°-60°

This characterization approach, while less than ideal (classification constraints), shows that there are zones of ERA optimality for given threat types. For slower, elongated EFP-type threats, the ideal triplate obliquity is in the 45°-75° range. For the faster, shorter SCJ-type threats, the ideal triplate obliquity is in the range of 15°-45°. This shows that ERA could achieve enhanced performance by having the ability to change its triplate obliquity to this range of angles. This ability would allow an ERA design to shave off parasitic capacity that would normally be built in to the ERA design to cover different ranges of threats. This characterization also showed that having the ability to readily change or modify the triplate cassette composition (mass, dimensions, explosives) gives additional adaptability to accommodate the multitude of current and emerging threat types. The factors that make an ERA perform well (mass, dimensionality and velocity) could all be adapted with the proper creation of adaptive mechanical means.

Map Adaptive Reactive Armor Factor Configurations to Components

The multitude of threat-armor-interaction scenarios have driven armor technologies toward a robust design state. Despite this robust state, static ERA designs only have applicability toward few threats, and that applicability comes at the expense of significant parasitic capacity. This parasitic capacity inhibits adjacent system of system functions such as strategic and tactical mobility. Integrating adaptive resilience along the three previously

discussed adaptive factors (explosive mass, armor plate mass, and dimensionality) into an adaptive ERA can mitigate this parasitic capacity. This section will discuss the mechanically adaptive and modular means to realize this adaptive resilience.

The first mechanical means that would facilitate both adaptive plate mass and explosive mass would be a modular ERA cassette array. This modular cassette array would be designed in a fashion that would accommodate variable ERA cassette thicknesses. A cassette range which could accommodate up to a 1 inch cassette would be suitable for most threat armor interaction scenarios. This modular cassette array could structurally house passive as well as energetic cassettes. This would provide the commander a way to scale down and mitigate the collateral risks associated with ERA while still providing capable kinetic energy threat protection. The modular cassette array could accommodate symmetric and asymmetric tri-plate ERA similar to what was shown in the previous section. Pre-designed, verified, and validated cassettes composed of differing armor plate thicknesses and explosive thicknesses could be available in the materiel supply/logistics system and could be assigned as additional components-of-end-item that would accompany the adaptive ERA system providing adaptive resilient protection and mobility to the user. This capability affords the user external re-configurability (adaptive mode 2) for resilient response to a complex operational environment. This would provide the user adaptive means that could be readily tuned and tailored based on the threat situation to maximize resilience. This same adaptability would provide a ready architecture that could receive new triplates or other multi-plate compositions tailored to address unknown or emerging threats.

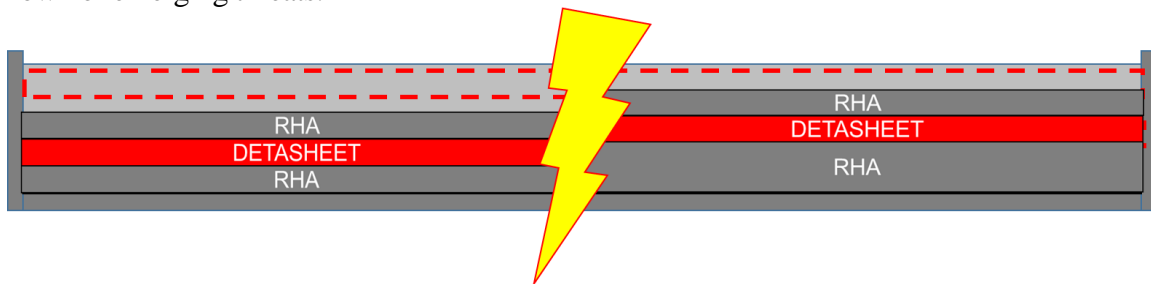

Figure 16. Multi-Cassette Array.

This figure is a conceptual depiction of a multi-cassette tray that can accept variable ERA triplate thickness allowing for rapid adaptation of triplate cassettes enhancing resilience to changing threat and operational requirements.

The multi-cassette array must have three key capabilities, the structural integrity to accommodate the maximum weight and impulse loads the heaviest of adaptive cassettes could impart upon it, the ability to rapidly remove and install new cassettes based on user requirements, and lastly a structural design that would minimize sympathetic and collateral detonation when the ERA cassettes detonate during a threat-armor-interaction. Briefly, a simple tray system with a quick-release retention pin, and polyurethane coated cassettes pre-designed to threat protection needed could serve as a capable early prototype.

The second mechanical means would address the dimensionality adaptive factor. This mechanical integration must allow the installed ERA cassettes to rapidly change their obliquity in an internal re-configurability mode (adaptive mode 1). The ability to do this in short operationally relevant timelines (in-situ) could allow the armor to react and achieve an optimal threat-armor-interaction obliquity. Envision a sensor system which could identify the spatial, temporal attributes, as well as identity of a slower incoming threat. This information could be fed to a central processing system that

references a database of optimal ERA threat-armor-interaction obliquities and tune the obliquity of the adaptive ERA system to that optimal design. This type of system would require a fast yet heavy duty drive system that could achieve these design points in operationally relevant timelines. Without going into specifics of a detailed design, a leaf chain, shaft and sprocket assembly could provide the structural architecture needed to drive the heavy armor plate loads in an operationally relevant timeline. This chain, shaft, sprocket assembly would have to be fitted with a suitable shaft actuation system that could rotate the shaft, sprocket, and therefore, ERA cassette arrays in a suitable fashion and time for the required threats... In order to maximize the degrees of adaptability, the drive system, chain-sprocket-shaft architecture would need to be compatible with the adaptive cassette array.

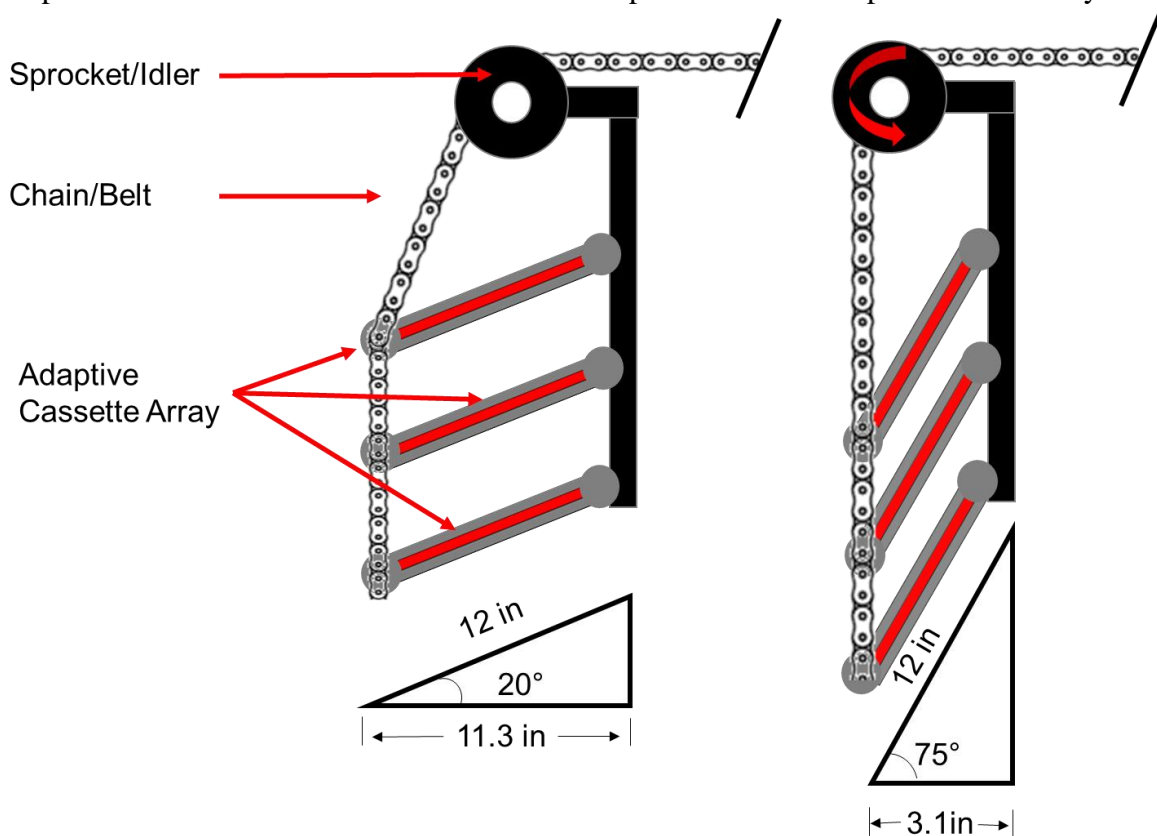

Figure 17. Conceptual Adaptive Resilient Explosive Reactive Armor.
This figure is a conceptual depiction of a chain-sprocket system which could vary ERA triplate obliquity allowing for rapid adaptation to changing threat and operational requirements.

With the adaptive cassette array and the drive-chain-sprocket-shaft assembly integrated into a holistic system, an enhanced ERA can be achieved which provides the user flexible armor protection ranging from passive to energetic, with a multitude of potential configurations armor plate and explosive configurations. This enhanced ERA system also provides the user a means to mitigate certain aspects of the parasitic capacity which accompanies contemporary ERA system designs that are fielded. Through adaptive dimensionality ERA has the potential to reduce the protruding width of an ERA system by over 70% (Figure 17: 11.3 in width to 3.1 in width). This would allow the host platform to better navigate narrow mobility corridors more easily, or overall vehicle width reduced to fit onto strategic transport platforms. The removable cassettes could be completely omitted for a

given operation or transport allowing more mobility or capacity/payload for other user operational needs. The adaptive resilient explosive reactive armor architecture provides the user with relevant operation to bring about more utility for the previously parasitic ERA systems.

CONCLUSION

Through this partial application of the MSIAR, it can be concluded that adaptive resilience could be used to enhance mature technology, enabling broader capability and usefulness. The adaptive resilient reactive armor concept proposed in this study, presents an opportunity for ERA developers to realize broader threat applicability, limited parasitic capacity, and minimizes impacts to host platform mobility. Controllable adaptive factors mapped to adaptive components squeeze greater performance from these mature technologies. The ability to adapt ERA cassette obliquities in rapid or real-time to optimal design points for identified threats; or the adaptation of ERA dimensionality to mitigate parasitic volume that inhibits host platform mobility (tactical and strategic), or through the adaptation of ERA cassette plate and explosive composition; are all way that ERA could realize enhanced performance for the complex operating environment.

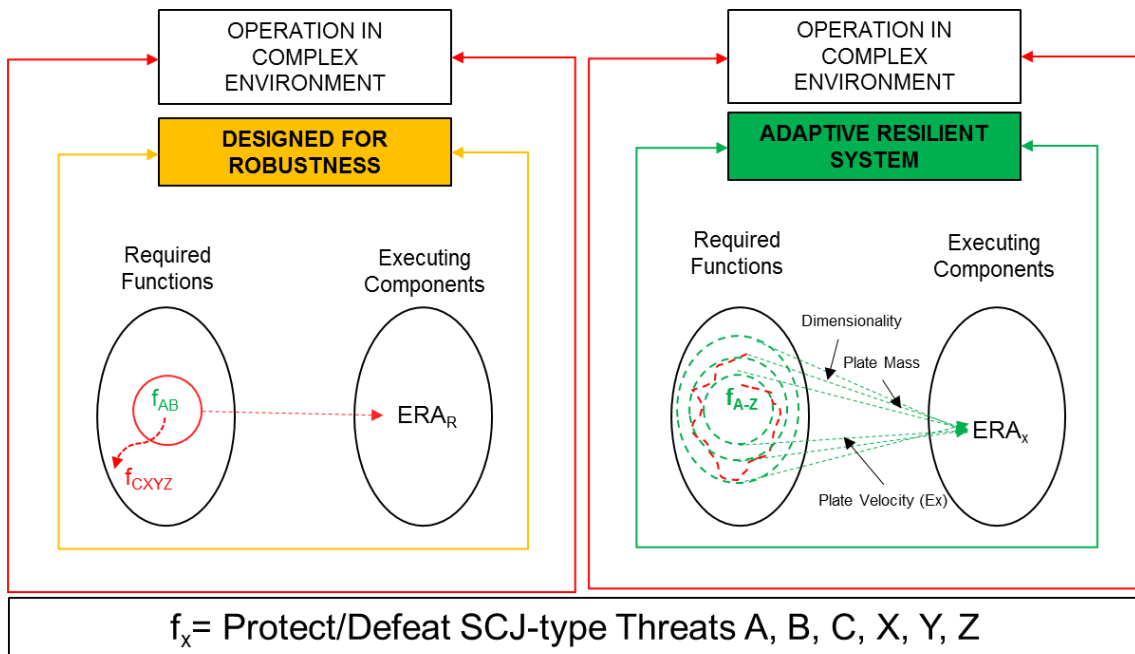

Figure 18. Adaptive Resilient Explosive Reactive Armor. This figure depicts how an adaptive resilient ERA system overcomes the challenges associated with operation in complex operating environments by creating a range of suitable functional performance enabled by adaptive physical components. The range of functional performance (concentric dashed ring) provide functionality in an extensible and scalable fashion beyond the functional requirement, or just enough to satisfy the requirement. This provides the user enhanced capability, over a robust-designed contemporary ERA systems which is fixed in its capability offering and laden with parasitic capacity (width, explosive/potential energy, weight) that is seldom used or required during operation.

Opportunities for future research on this topic include modeling and simulation or live fire test and evaluation verification and validation of specific cassette designs against recognized threats. These tests and experiments would truly show the value of this ERA concept’s adaptive resilience. Research and engineering of a sensor, processor, control and actuation system tuned to actuate the

adaptive resilient armor to design points of interest for those existing recognized threats would also serve as a great demonstration of the enhanced capability. Lastly, detailed engineering work on the physical and mechanical structure of the system so that it could withstand the operational loads associated with installation on a vehicle would move this conceptual technology towards realization.

REFERENCES:

- [1] Cannon, Joseph. *Methodology for the System Integration of Adaptive Resilience*, Naval Postgraduate School, 2016
- [2] Jackson, Scott. *Architecting Resilient Systems: Accident Avoidance and Survival and Recovery from Disruptions*. Hoboken, NJ: John Wiley & Sons, 2009.
- [3] W.P. Walters and J.A. Zukas, *Fundamentals of Shaped Charges*, John Wiley & Sons, New York, 1989.
- [4] Wikipedia, Reactive Armour, https://en.wikipedia.org/wiki/reactive_armor, Image, 2017
- [5] Burns, Bruce. *Advanced Ballistics Science and Engineering*. Aberdeen Proving Ground, MD: Army Research Laboratory, 2008.
- [6] Cooper, Paul W. *Explosives Engineering*. New York: VCH Publ., 1996. Pg. 384-387

Disclaimer: Reference herein to any specific commercial company, product, process, or service by trade name, trademark, manufacturer, or otherwise, does not necessarily constitute or imply its endorsement, recommendation, or favoring by the United States Government or the Department of the Army (DoA). The opinions of the authors expressed herein do not necessarily state or reflect those of the United States Government or the DoA, and shall not be used for advertising or product endorsement purposes.